



PLANT SCHEDULE			
NUMBER	QTY	COMMON NAMES	SCIENTIFIC NAME
P01	58	GERANIUM	PELARGONIUM
P02	89	YEW	TAXUS



COLUMBARIUM'S BY "ARCHITARIUM"
888.310.2038

12" X 12" X 12" FLAT WALL INSERT
8 UNITS PER COLUMN

SCOPE OF WORK
PROPOSAL FOR A FENCE WITH BRICK PIERS AS INDICATED WITHIN THESE DRAWINGS.

DESIGN LOADS
40 LIVE 10 DEAD - FIRST FLOOR
30 LIVE 10 DEAD - SECOND FLOOR
20 LIVE 10 DEAD - ROOF
100 MPH (38 LBS) - WIND

NOTES:
-ALL LUMBER SHALL BE DOUGLAS FIR #2
-ALL NON-STRUCTURAL METAL STUDS SHALL BE 25 GAUGE

THESE PLANS REFERENCE:
-UNIFORM CONSTRUCTION CODE NJ
-REHABILITATION SUB-CODE NJAC 5.23-6
-NJ IRC 2018 BUILDING CODE
-NJ EC 2017 CODE
-SMOKE DETECTOR NOTES:
NO WORK

A2 - USE GROUP
5B - CONSTRUCTION CLASS
NC - SQUARE FOOTAGE
NC - VOLUME

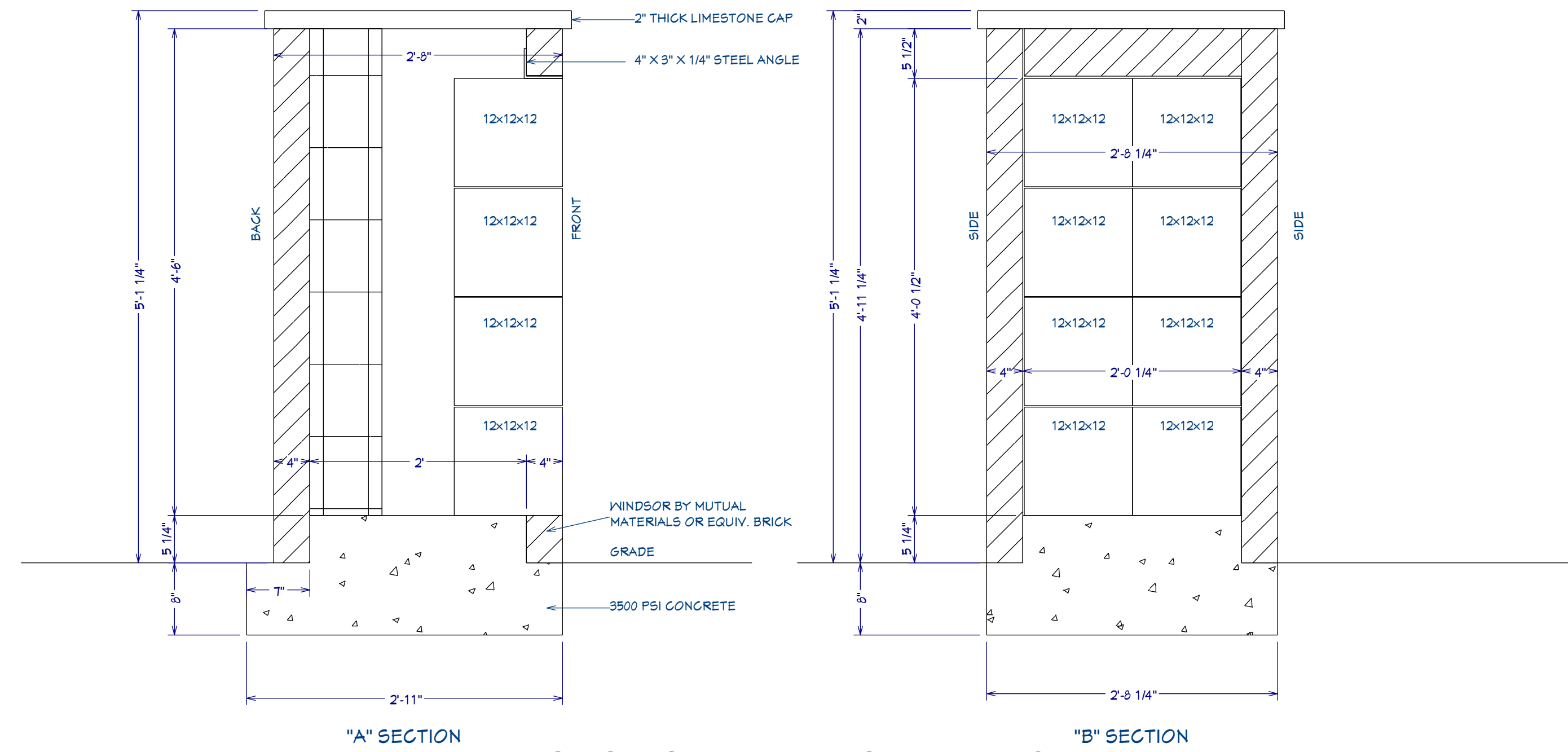

SECTION DETAILS 1 in = 1 ft

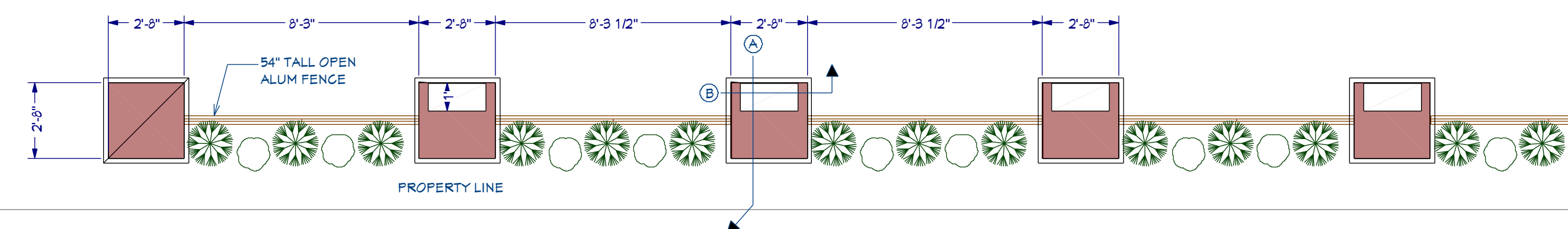

PLAN 1/4 in = 1 ft

© COPYRIGHT NOTE
1. No part of this drawing shall be reproduced, stored in a retrieval system, or transmitted in any form or by any means, electronic, mechanical, photocopying, recording, or by any information storage and retrieval system, without the prior written consent of the architect.
2. This drawing is the property of the architect and shall remain the property of the architect. It is to be used only for the project and site identified on the drawing. It is not to be used for any other project or site without the prior written consent of the architect.
3. No part of this drawing shall be used for any other project or site without the prior written consent of the architect.
4. No part of this drawing shall be used for any other project or site without the prior written consent of the architect.
5. No part of this drawing shall be used for any other project or site without the prior written consent of the architect.

NO.	DESCRIPTION	DATE	BY
1	REDUCE LENGTH OF FENCE/PIERS	5.11.2023	
2			
3			
4			
5			

Marcille Architecture
505 Main Street
Second Floor Metuchen NJ 08840
732-562-5824
mark@mm-arch.com
6th Ave Seaside Park, NJ 08752

PROJECT DESCRIPTION:
First Presbyterian Church of Metuchen
270 Woodbridge Ave
Metuchen, NJ 08840
Job No 20-118 Ideal first presbyterian



NJ LICENSE # 16478
PA LICENSE # 40392

DATE:
03.18.2021
SCALE:
AS NOTED
SHEET:

GENERAL NOTES AND SPECIFICATIONS

THE CONTRACTOR SHALL ASSUME FULL RESPONSIBILITY FOR ANY WORK KNOWINGLY PERFORMED CONTRARY TO SUCH LAWS, ORDINANCES, OR REGULATIONS. THE CONTRACTOR SHALL ALSO PERFORM COORDINATION WITH ALL UTILITIES AND STATE SERVICE AUTHORITIES.

WRITTEN DIMENSIONS ON THESE DRAWINGS SHALL HAVE PRECEDENCE OVER SCALED DIMENSIONS. THE GENERAL CONTRACTOR SHALL VERIFY AND IS RESPONSIBLE FOR ALL DIMENSIONS (INCLUDING ROUGH OPENINGS) AND CONDITIONS ON THE JOB AND MUST NOTIFY THIS OFFICE OF ANY VARIATIONS FROM THESE DRAWINGS.

THE GENERAL CONTRACTOR IS RESPONSIBLE FOR THE DESIGN AND PROPER FUNCTION OF PLUMBING, HVAC AND ELECTRICAL SYSTEMS. THE GENERAL CONTRACTOR SHALL NOTIFY THIS OFFICE WITH ANY PLAN CHANGES REQUIRED FOR DESIGN AND FUNCTION OF PLUMBING, HVAC AND ELECTRICAL SYSTEMS.

THIS OFFICE SHALL NOT BE RESPONSIBLE FOR CONSTRUCTION MEANS AND METHODS, ACTS OR OMISSIONS OF THE CONTRACTOR OR SUBCONTRACTOR, OR FAILURE OF ANY OF THEM TO CARRY OUT WORK IN ACCORDANCE WITH THE CONSTRUCTION DOCUMENTS. AND DEFECT DISCOVERED IN THE CONSTRUCTION DOCUMENTS SHALL BE BROUGHT TO THE ATTENTION OF THIS OFFICE BY WRITTEN NOTICE BEFORE PROCEEDING WITH WORK. REASONABLE TIME NOT ALLOWED THIS OFFICE TO CORRECT THE DEFECT SHALL PLACE THE BURDEN OF COST AND LIABILITY FROM SUCH DEFECT UPON THE CONTRACTOR.

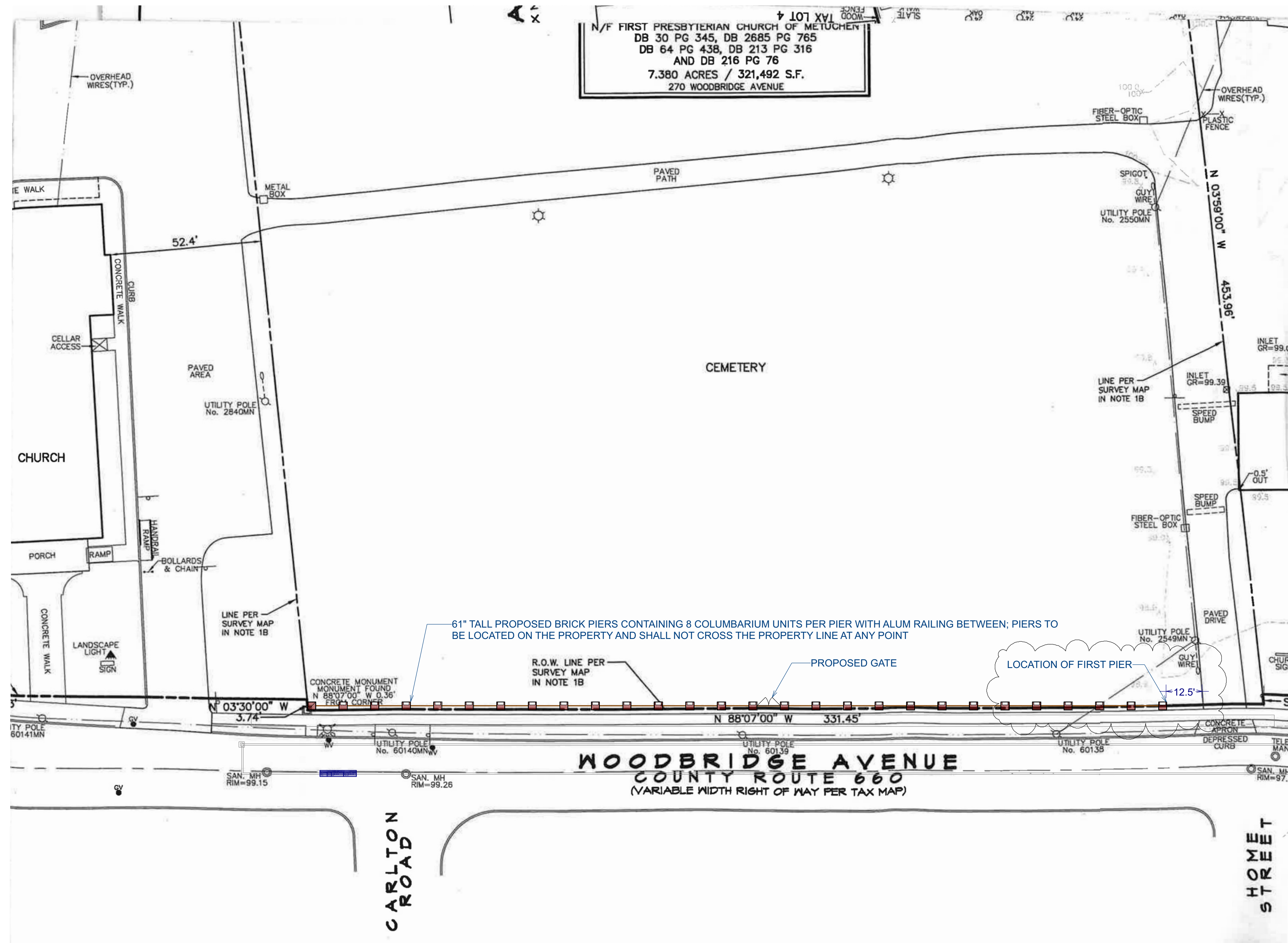

PLOT PLAN 1 in = 20 ft

© COPYRIGHT NOTE
 1. No part of this drawing shall be reproduced, stored in a retrieval system, or transmitted in any form or by any means, electronic, mechanical, photocopying, recording, or by any information storage and retrieval system, without the prior written consent of the author.
 2. This drawing is the property of the author and shall remain the property of the author. No part of this drawing shall be reproduced, stored in a retrieval system, or transmitted in any form or by any means, electronic, mechanical, photocopying, recording, or by any information storage and retrieval system, without the prior written consent of the author.
 3. The author shall not be held responsible for any errors or omissions in this drawing, and shall not be held responsible for any damage or injury resulting from the use of this drawing.
 4. The author shall not be held responsible for any damage or injury resulting from the use of this drawing.

NO.	DESCRIPTION	BY	DATE
1	REDUCE LENGTH OF FENCE/PIERS		5.11.2023
2			
3			
4			
5			

Marcell Architecture
 505 Main Street
 Second Floor Metuchen NJ 08840
 732-562-5824
 mark@marcell-arch.com
 6th Ave Seaside Park, NJ 08752

PROJECT DESCRIPTION:
 First Presbyterian Church of Metuchen
 270 Woodbridge Ave
 Metuchen, NJ 08840
 Job No 20-118 Ideal first presbyterian



NJ LICENSE # 16478
 PA LICENSE # 40392

DATE:
 03.18.2021
SCALE:
 AS NOTED
SHEET:

A-2